

STEP 8 - ATTACHING GUARD RAILS (if necessary)

Bil-Jax recommends guard rails on the stage when the stage height exceeds 24”.

Section 1015 of the International Building Code (IBC) **requires** the use of guard rails with vertical posts no greater than 4” apart when the stage height exceeds 30”.

- A) Determine which side(s) need guard rails. If snap pin used to attach leg is accessible, temporarily remove it.
- B) Place guard rail against side of deck. Reattach snap pin through hole in guard rail mount plate.
- C) Insert $3/8" \times 2-1/2"$ bolt through other hole in guard rail mount plate and stage deck leg socket. Attach and tighten the hex nut. **Note: Bolt is required. Snap pin alone is insufficient.**
- D) Insert $3/8" \times 1"$ bolt through other hole in guard rail mount plate and side plate of stage deck. Attach washer and tighten the hex nut.
- E) Where guard rails meet at a corner, snap pin used to attach leg is completely removed.
- F) Repeat Step 8 until all guard rails are attached.

! WARNING ! – Failure to correctly install guard rails could result in serious injury or death. Verify that each guard rail is properly installed and hex nuts are tightened.

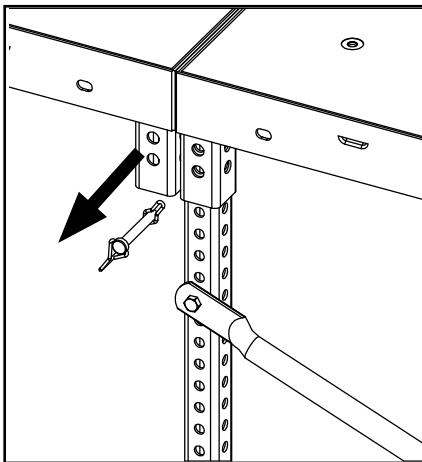
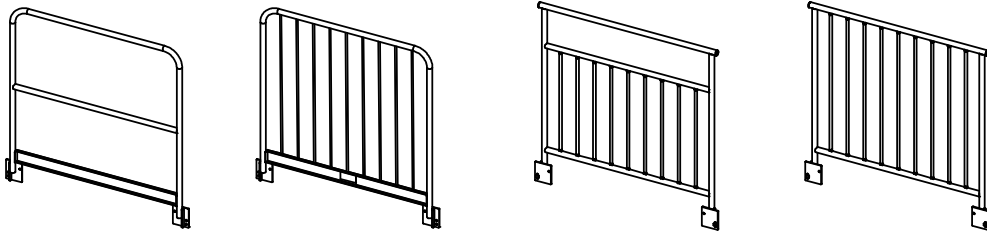

A

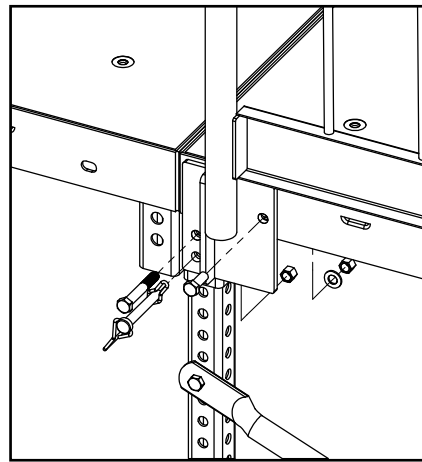

B C D

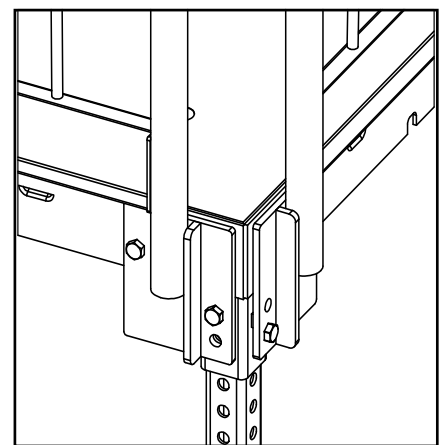

E