

STEP 9 - ATTACHING GUARD RAILS (if necessary)

Bil-Jax recommends guard rails on the stage when the stage height exceeds 24”.

Section 1015 of the International Building Code (IBC) **requires** the use of guard rails with vertical posts no greater than 4” apart when the stage height exceeds 30”.

- A) Set the lower lip of the two guard rail locks inside the stage deck channel along the perimeter of the stage decks.
- B) Pivot guard rail toward the stage until there is a “click” sound. This fully seats the T-Lock within the stage deck channel. Press down on plunger if necessary to seat T-Lock.
- C) Tighten the hex nut on each lock to fully secure guard rail.
- D) To remove guard rail, loosen hex nuts, depress T-Lock plungers and pivot guard rail away from stage.

! WARNING ! – Failure to correctly install guard rails could result in serious injury or death. Verify that each T-Lock is fully seated inside the stage deck channel and hex nut is tightened.

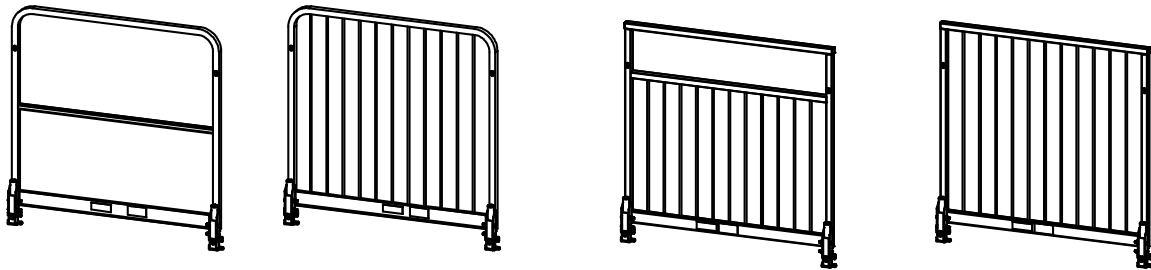

A

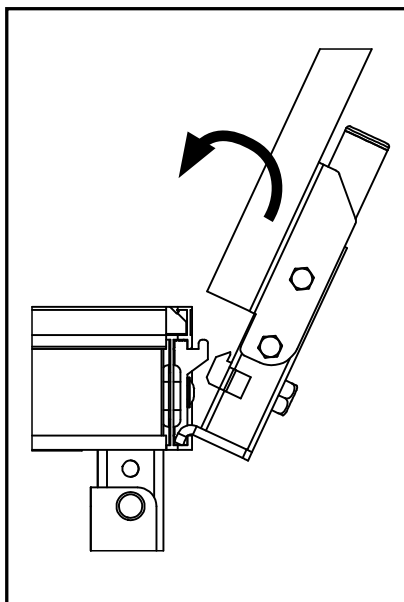

B

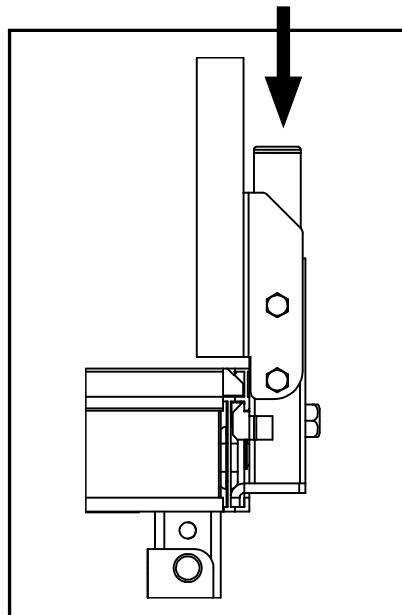

C

